



ROUTER TOOL

USER'S GUIDE

CREATE FAST AND ACCURATE SQUARE OR RECTANGULAR JIGS FOR:

- FLUSH MOUNTING HEADUNITS
 - VIDEO SCREENS UP TO 12"
 - MEDIA CHANGERS
 - SATELLITE RADIO CONTROLLERS
 - POWER STORAGE CAPACITORS
 - SMALL FOOTPRINT AMPLIFIERS
 - PASSIVE CROSSOVER NETWORKS
 - SLOT PORT GRILLES
 - APPLE IPOD AND OTHER PORTABLES
 - DAKOTA DIGITAL GAUGES
 - A'PEXÍ ELECTRONIC CONTROL UNITS
 - ROUTER TABLE MOUNTING PLATES
 - IN WALL HOME SPEAKERS
 - IN WALL VOLUME CONTROLS
 - HOME ENTERTAINMENT TRIM PANELS
-AND SO MUCH MORE!



Distributed Exclusively by:



AIR 93 FRNT 93
Psi 74 REAR 74

Thank you for purchasing the Fukuda Router Tool

Whether you are just starting out in custom installations or are a seasoned veteran, you can quickly appreciate the value of an innovative, time saving tool or process that makes your work look totally professional. The Fukuda Router Tool is one such item and we're proud to offer this to installers of all consumer electronic products involved with some level of custom fabrication. Besides saving time and helping you be more consistent, we're also focused on safety and reliability of our installation tools and processes. We think you'll find that when professionals have a choice, they'll choose Fukuda tools because there's simply nothing else like them!

The Fukuda Router Tool will help you make more consistent square and rectangular cut outs or jigs than just about any other method currently out there. With a coverage of 1ft² (12" x 12"), the possibilities for your applications include video screens, headunits, signal processors, small footprint amplifiers, power supply capacitors, rectangular gauges, rectangular in-wall speakers, or just about any other application that fits in a 1 square foot area.

In addition to square and rectangular applications, the Fukuda Router Tool, in combination with circle cutting tools, will allow you to find center on just about any circular item up to 12" in diameter and cut the perfect hole. Applications include round gauges, subwoofers up to 12", round speakers of all types, and just about any other round shape that fits in a 12" diameter.

For the best results when using the Fukuda Router Tool, we recommend that you have a router installed (inverted) in a table. While this is somewhat common in most fabrication shops, not all shops have made the investment of an inverted router table. Additionally, for the tight corners associated with many of the square and rectangular shapes, we recommend the finish trimming be done with a 1/4" spiral flush trim bit to maintain the symmetry of the original corner radius.

Please read this user's guide carefully and completely. Doing so will allow you the greatest use of your Fukuda Router Tool while doing so in a safe and trouble free manner. If you have additional questions about using the tool or for a greater range of creative applications, we encourage you to enlist in a Mobile Solutions Fabrication Training seminar. Mobile Solutions is the exclusive distributor of the Fukuda Router Tool and has trained hundreds of technicians on its many time-saving uses in custom fabrication applications. You can find more information about Mobile Solutions training and the Fukuda Router Tool at www.mobilesolutions-usa.com.

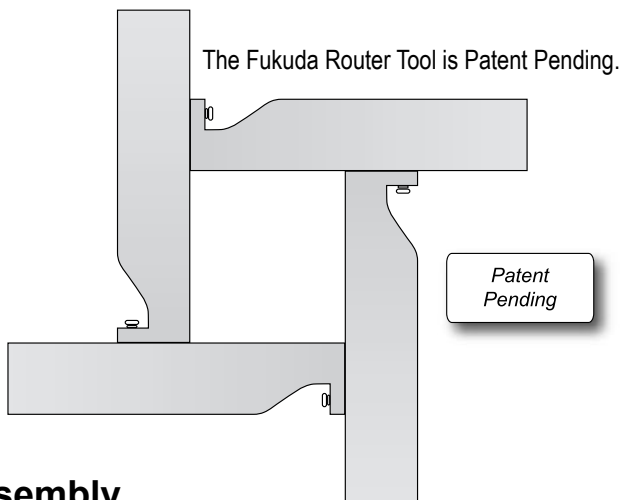

The Fukuda Router Tool is distributed exclusively by Mobile Solutions

Mobile Solutions
Tel - (206) 714-7828
www.mobilesolutions-usa.com

Assembly

Your Fukuda Router Tool is shipped un assembled, but there is very little assembly required.

- 1) Lay all the pieces upside down on a flat table. The "Fukuda" logo side is down facing the table.
- 2) Remove the 3/32" Allen button head machine screws (the "stop" screws) on each piece. This will allow the parts to slide into the groove.
- 3) Make sure the plastic thumbscrews are loose enough so they do not inhibit movement of a joining piece.
- 4) Form a square and slide 2 pieces together. (See Diagram)
- 5) Next slide the 2 other pieces together.
- 6) Next, carefully align and slide the 2 corners pieces together so that all 4 pieces join. (See Diagram)
Note: Take your time on this step because the aluminum arms must be in perfect alignment to complete the assembly.
- 7) Once assembled as a square, reinstall the stop screws and test the tool for sliding. The tool is now ready for use.

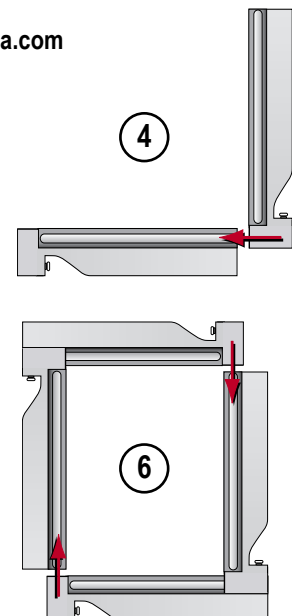

If you experience any problems with assembly, please contact Mobile Solutions for assistance.

General Guidelines

There are some general guidelines for using the Fukuda Router Tool properly.

- 1) Whenever you are sizing the Fukuda Router Tool around an object, be sure to CAREFULLY loosen and tighten the plastic thumbscrews. These keep the tool stationary during trim out with the router and since the bearing of the router must ride on the aluminum surface of the tool, the thumbscrews should be tight enough to ensure the tool does not move BEFORE it is attached to the substrate material. If you ever break these from over tightening, replacements are easy to find at any hardware store or home center with a "bin style" hardware selection. (Ace, True Value, Home Depot, Lowe's, etc.)
- 2) You can attach the Fukuda Router Tool to virtually any substrate material used in fabrication that can be cut with a rotary cutter like a router, Roto-Zip, or Dremel. MDF is probably the most common, but ABS and acrylic plastics, aluminum, laminates, even drywall could be used. The most important part of cutting your substrate is that it's completely attached to the tool. When attaching the tool to the substrate material, 2 sided "pressure sensitive" adhesive tape (such as Kent, Bron, 3M, or Mobile Solutions Template Tape) is recommended. It's not necessary that the tape has considerable thickness, but it is best if the tape can be easily torn or cut once placed on to the tool. This is why Mobile Solutions recommends using their template tape (MS Part#TDST5). Whatever 2 sided tape you choose, use caution when cutting the tape with a razor knife once attached to the tool as this may cut into the aluminum surface of the tool.
- 3) Whenever trimming any shape with the router using the Fukuda Router Tool, we always recommend ROUGH CUTTING the opening of the substrate so the flush trim router bit only has to do the "finish" work. When rough cutting, use a jig saw and leave 1/8" -3/16" edge for the router bit to finish trim. By completing the rough cut operation, you gain 2 inherent benefits. First you can cut and control your substrate more accurately (particularly with hard plastics or aluminum sheet). Second, you extend the life of your router bits because they essentially only cut on half of the rotation instead of pushing the bit through a complete sheet of the substrate. Remember jigsaw blades are much cheaper than high quality carbide router bits!
- 4) When trimming intricate openings, you will often find that a 1/2" flush trim router bit leaves too large a radius on the inside edges of your square or rectangle shape. For this reason, we recommend having smaller 1/4" and 1/8" spiral flush trim router bits on hand to complete the required corner radius without having to sand or file to fit. Mobile Solutions offers both 1/4" and 1/8" spiral flush trim bits for this task. If you look close in the photo, you will see the effect of a corner trimmed with a 1/2" flush trim bit and how the radius in the corner may not fit the opening flush for something like a video screen, signal processor, or a similar application. Nearly all aftermarket headunit trim applications (for example) require a 1/4" or 1/8" bit trim to fit properly in the opening created by the Fukuda Router Tool.
- 5) This photo shows the 1/4" spiral "upcut" flush trim bit in a router table application using a zero clearance insert. This spiral flush trim bit is available from Mobile Solutions (MS Part# 120-0412) and is also available in a 1/8" version for VERY tight corners (MS Part# 120-0212). Remember that a 1/2" bit will give a 1/4" radius, a 1/4" bit will give a 1/8" radius (which is the most common), and the 1/8" bit will give a 1/16" radius. If you are unsure of the radius, you can use Mobile Solutions Radius Gauges (MS Part# RG-SM) to verify the radius so you select the correct router bit on the first try.

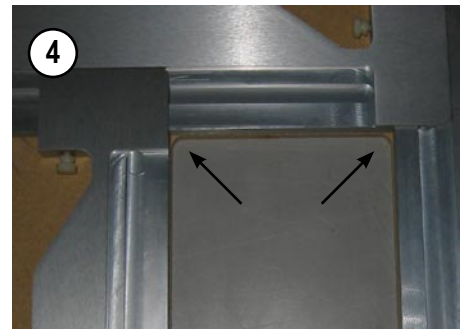
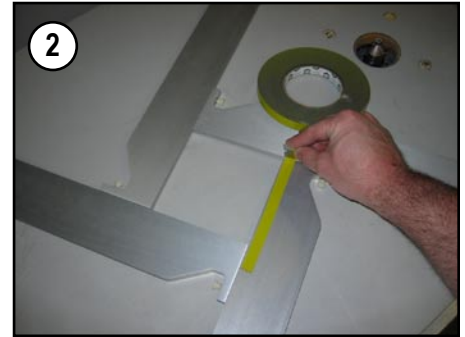
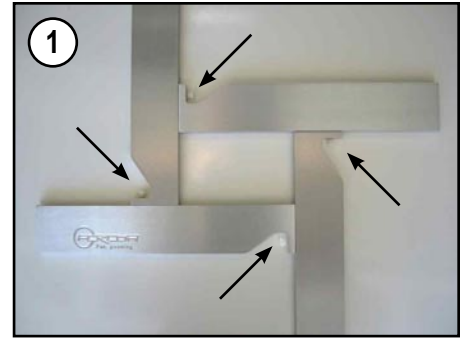

Using the Mobile Solutions Radius Gauges will allow you to select the appropriate router bit for the radius of the shape you are working with. The small radius gauge set includes: 1/8", 1/4", 3/8", 1/2", 3/4", 1", 1.5", and 2" sizes.



Inside Shapes (Cut-Outs)

This sequence shows the Fukuda Router Tool performing the cutting guide for an EXACT FIT cut out on a square or rectangular shape. In the example shown, a trim ring for an LCD monitor is demonstrated. In actual practice, the opening could be for virtually anything that is square or rectangle in shape.

- 1) Position the tool around the object for which you want to build a "snug" fitting panel and push the rails inward until it's tight against the object. At this time tighten the plastic thumbscrews.
- 2) Now take the tool over to your substrate material (MDF, plastic, etc.) and lay it over the material (upside down) so you can mark the opening for rough cutting. You need not apply adhesive tape at this time as you will not be doing any cutting yet. Mark the opening with something that will show up adequately when performing the rough cut.
- 3) Use the appropriate eye protection at this time (safety glasses, etc.). Drill a hole in each corner of the marked area leaving about 1/8"-3/16" spacing from the marked line of the edge. Using your jig saw, carefully cut out the middle section leaving that necessary spacing of 1/8"-3/16" around the edge. This will be the trimming job of the router bit once the router tool is in place as the guide.
- 4) Prepare your substrate for attachment with the tool by wiping away any residual dust from the rough cutting operation. Peel and stick the 2 sided tape to the tool first and press it firmly into place on the aluminum arms. Once completed, peel away the second layer of the tape and position the tool over the rough cut opening. Take your time when doing this part because the 1/8"-3/16" edge does not leave much room for error.

Note: It is not advised to stick the tool down to the substrate and lift it again for repositioning. If the tool must be repositioned, use new 2-sided tape.

- 5) Take the tool and substrate combination over to the router table and lay the open area over the router bit. Adjust the router height so the flush trim bearing RIDES ON THE ALUMINUM of the tool arm. After the router is sufficiently adjusted, pull the tool away from the router bit and hold it firmly in place while you start the router. Remember you should be wearing eye protection before turning on the router!! Once the router is turned on, follow the pattern below coordinate your cutting movements.

Begin at the bottom edge of the tool, **moving to the left**, then up across the top, and back down the right side. Complete trimming by going around another pass to ensure you did not miss any material. Beginning at the bottom (closest to you) lets you safely align the bearing on the tool.

Once completed, remove the tool from the substrate and test fit your part. It should fit perfectly if you have used the correct diameter bit for the corners. After the opening is finished, you can move on to completing the panel in whatever fashion you wish. This example was further trimmed on the outside edges with another template for a trim ring.

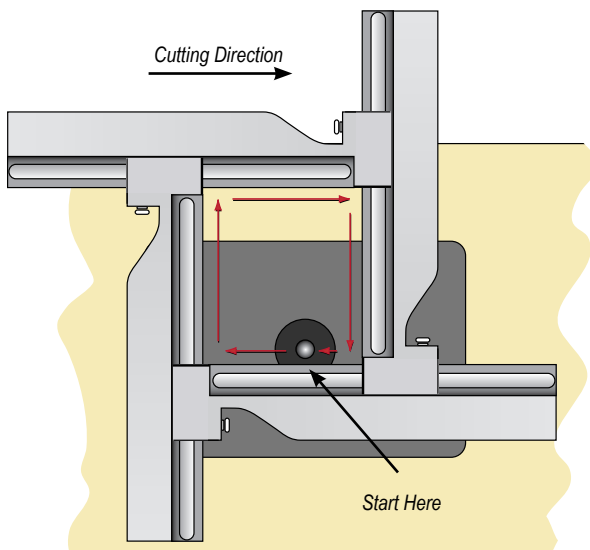

Example of the Finished Product

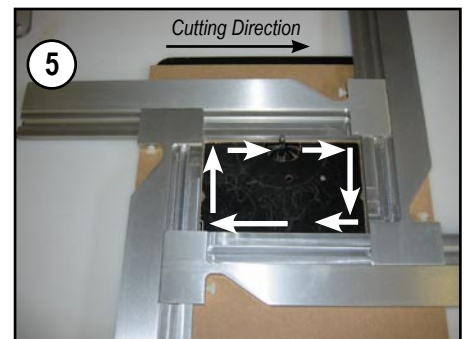
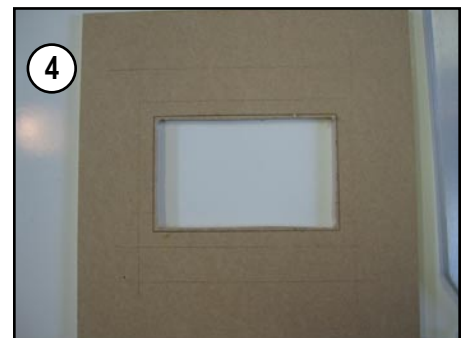
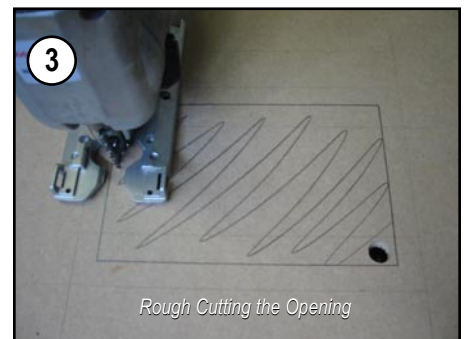
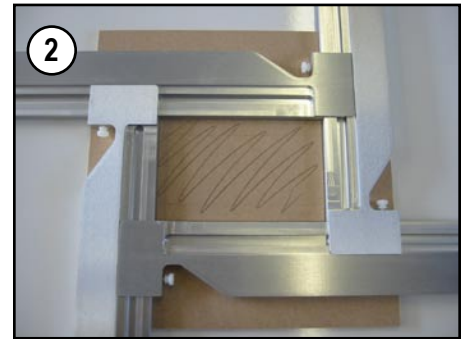

Perfect Fit Speaker Holes

This sequence shows the Fukuda Router Tool performing the means by which exact mounting diameter holes for speakers up to 12" can be determined. Additional tools are required to complete the full speaker hole cutting operation. You will also need the Perfect Circle (MS Part#RA-PCIR) and a measuring tape or ruler.

- 1) Lay the speaker you wish to measure on a flat surface (cone facing down). Once it is in position, use the Fukuda Router Tool by adjusting it up to the sides of the speaker. Once snug and in place, the tool should touch the speaker frame in the middle of each aluminum arm. Tighten the plastic thumbscrews at this time.
- 2) The next step is to measure the opening of the tool. You can do this with a tape measure or a ruler. (Mobile Solutions "Center Finding Rule" is shown). Once you have the dimension, mark it down on a piece of paper for your records.
- 3) Next, you will transfer that measurement to your baffle plate in which the speaker will install. Draw an X where both measurements meet in the middle. The middle of the X will be the middle of the speaker opening.

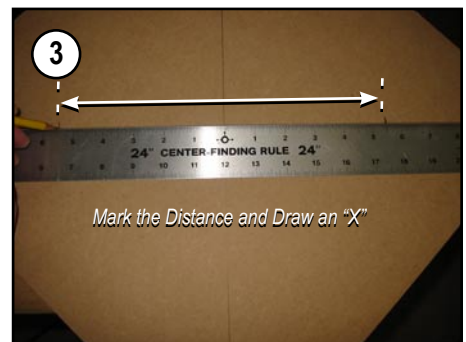
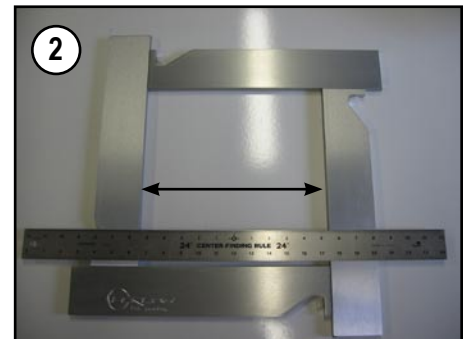
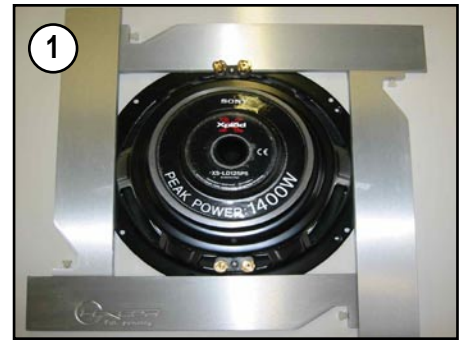

Note: If you are building an enclosure with a flat baffle, it's highly recommended that you do the speaker cut out BEFORE assembly of the enclosure. Doing so will make it much easier to gain access to the inside for sealing and/or bracing.

- 4) Next, drill a small 1/8" pilot hole in the center of the X. Once completed, you must set up the handheld router mounted to the Perfect Circle to the appropriate diameter for the circular cut. Place the pivot pin in the center hole. Loosen the tension nut for the pivot arm and slide the router out to the edge of your "X" measurement. Once the circle guide is positioned correctly for the cutting diameter, tighten the tension nut.
- 5) Use the appropriate eye protection at this time (safety glasses, etc.). Make the VERY FIRST pass with only a small cutting depth (1/16" or less) so you can verify that you are on target with the marking. Now you can begin the cutting process by setting the router depth on the initial plunge for just 1/4" or less. Do not try to plunge the router and make the cut in one single pass. Make three or four passes (for 3/4" thick material as shown here). After the first pass, plunge the router bit another 1/4" and run the pass again. Repeat this (as shown) until the cut is complete.



Note: Since you will be cutting through the material completely, it may be helpful to have a scrap piece of MDF on the table below attached with 2 sided tape to the baffle so the router bit does not cut into the table. The 2 sided tape will keep the inside MDF from moving when the cut is complete and will ensure an additional measure of safety.

Once the cut is completed, you should test fit the speaker to make sure it fits as you planned. If you've measured correctly and transferred those measurements to the baffle properly, you should have a very tight fit for the speaker that snugs right round the frame. This type of speaker mounting hole cutting method is particularly well suited for large, heavy subwoofers where the tight fit around the frame takes some of the stress off of the hardware used in mounting the woofer. When used with the manufacturer supplied mounting gasket, it also ensures an air tight seal which further improves the performance of all speakers, whether mounted in an enclosure, a door, or rear deck.

You can also use this technique to make mounting templates for every speaker you may sell in your shop so you always have the right mounting diameter on hand for future projects.



This process can also be used for creating perfect fit door speaker adapters



Example of the Finished Product

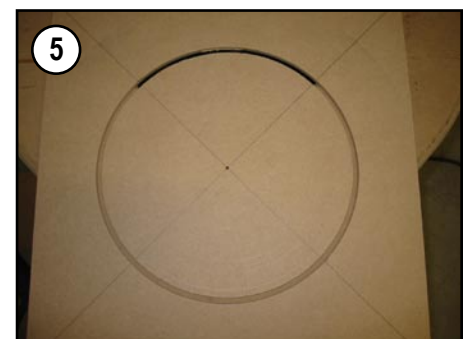

Applications for the Fukuda Router Tool



Dakota Digital Gauges



Making Complete Custom "Perfect Fit" Headunit Trim Panels from Scratch



iPod Flush Mounting



Making Cosmetic Trim Rings for Headrest or Sun Visor LCD Monitors



Trimming out Media Changers



Flush Mounting Satellite Radio Controllers



Making Cut-Out Jigs for Complex Dash Work



Flush Mounting Boost Controllers and Turbo Timers

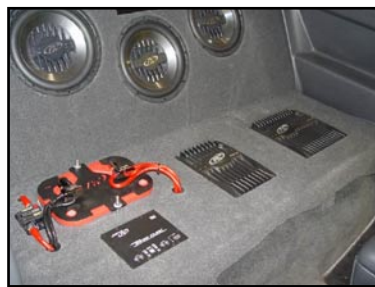

Flush Mounting Small Footprint Amplifiers, Signal Processors, Passive Crossovers, etc.



Flush Mounting Power Distribution Components, Power Supply Capacitors, etc.



Creating Cut-Out Templates for In Wall Rectangular Speakers

.....and soooooo much more. The only limitation is really your imagination!





SPECIALTY FABRICATION TOOLS AND ACCESSORIES

Manual Version 1.31, 10/2005

Distributed Exclusively by



Mobile Solutions • Tel - (206) 714-7828 • www.mobilesolutions-usa.com